



EXPLANATION OF SYMBOLS

REF Reorder Number

LOT Batch Code

 Use-by date

 Do not resterilize

 Do not reuse

 Consult instructions for use

 Do not use if package is damaged

 Not made with natural rubber latex

 Caution

Rx Only U.S. Federal Law restricts this device to sale by on the order of of a physician

STERILE EO Sterilized using Ethylene Oxide

 Manufacturer

ZUI 4.0™

Zinnanti Uterine Injector

For such procedures as Hysterosalpingograms,
Salpingoplasties and Hydrotubation

REF ZSI1152

Instructions For Use

- A Air Valve and Balloon Assembly
- B Endport
- C Inflatable Cuff
- D Centimeter Markings
- E Cervical Stop
- F Luer Lock fitting

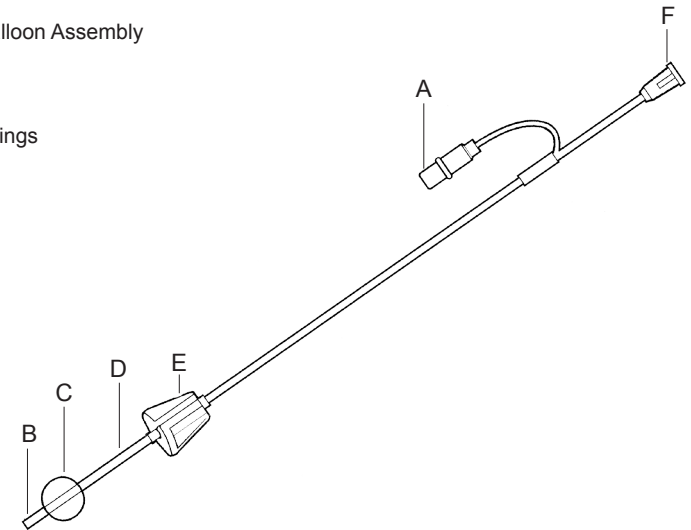

LENGTH: 23 cm (9")
OD SIZE: 4.0 mm

DESCRIPTION

ZUI 4.0 (Zinnanti Uterine Injector) is a single-use, sterile/disposable, clear polyvinyl chloride uterine injector which meets USP recommendations for implant testing. This product is designed with a double-lumen, one for inflation of a 5 cc intrauterine cuff and the other for injection of fluid through a distal endport. The product is slightly curved to facilitate easy entrance into the uterus through the cervical canal. The product features an inflation valve and pilot balloon assembly (A), an endport (B), an inflatable cuff (C), centimeter depth markings (D), a removable cervical stop (E), and a luer fitting to accommodate a syringe (F). The device has a length of 23 cm and an outer diameter of 4.0 mm.

ZUI 4.0™ is a registered trademark of CooperSurgical, Inc.
© 2016 CooperSurgical, Inc.

CooperSurgical

95 Corporate Drive • Trumbull, CT 06611 USA
Phone: (800) 243-2974 • Fax: (800) 262-0105
International Phone: (203) 601-9818 • Fax: (203) 601-4747
www.coopersurgical.com

INDICATIONS FOR USE

ZUI 4.0 (Zinnanti Uterine Injector) is indicated for in-office or hospital use when efficient sealing of the uterine cervix is required for the injection of liquid or gas such as hysterosalpingography, salpingoplasties, hydrotubation and Rubin's Test. ZUI 4.0 can be used without cervical dilation or anesthesia if the uterus can be sounded easily with a standard uterine sound.

CONTRAINDICATIONS

ZUI 4.0 should not be used in pregnant patients, in patients suspected of being pregnant or in the case of uterine or tubal infection.

WARNINGS

Insure that the snap-on cervical stop (**E**) is secured to the catheter with the flat face of the cervical stop well fixed on the tube at the 6 cm mark (see Figure 1). (It is possible that the stop may become loosened from shipment or improper handling. It is easy to snap back on at the 6 cm mark before usage). To avoid uterine trauma, thread the ZUI 4.0 along the natural axis of the cervical canal. To reduce the possibility of missing the natural axis of the cervical canal, be sure to sound the uterus prior to using this device.

For single use only. Do not reuse, reprocess or resterilize. Reuse, reprocessing or resterilization may compromise the structural integrity of the device and/or lead to device failure which, in turn, may result in patient injury, illness or death. Reuse, reprocessing or resterilization may also create a risk of contamination of the device and/or cause patient infection or cross-infection, including, but not limited to, the transmission of infectious disease(s) from one patient to another. Contamination of the device may lead to injury, illness or death of the patient. Dispose of in accordance with all applicable Federal, State and local Medical/Hazardous waste practices.

PRECAUTIONS

Inflate uterine cuff (**C**) to check for leakage before insertion. Lubricate distal end (cuff and catheter) for easy insertion. Observe manufacturer's directions and precautions pertaining to any liquid media or gas that is being injected into the patient. After removal of this product following a procedure **ALWAYS** inspect the device for intactness.

ADVERSE REACTIONS

Uterine spasm with accompanying temporary physiologic blockage of patient's fallopian tubes.

- Cramping
- Infection
- Perforation of uterine wall

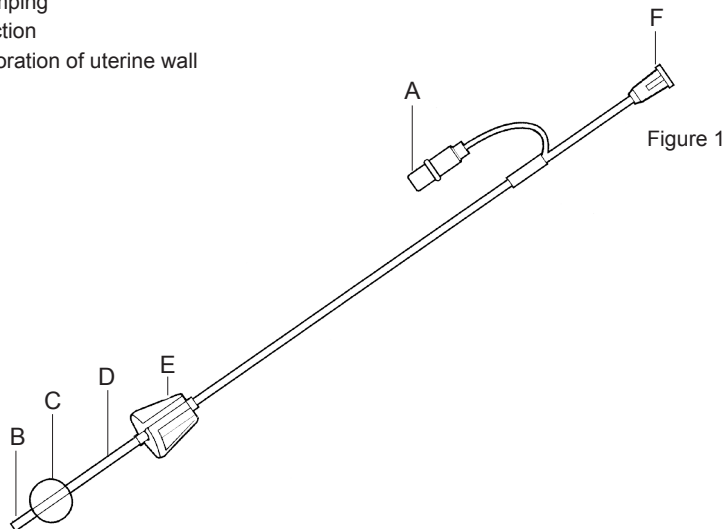

Figure 1

INSTRUCTIONS FOR USE

1. Check to see that the sterile pouch containing the ZUI 4.0 Uterine-Injector has not been punctured or damaged thus compromising sterility.
2. Inspect carefully to ensure that the cervical stop (**E**) is securely in place with the face at the 6 cm mark. If the stop is not fixed and slides easily, snap it securely in place before using.
3. Using a standard plastic syringe, inflate the cuff (**C**) with 5 cc of air to check for leakage before inserting into patient. Air is injected through the valve assembly.
4. After checking inflatability, evacuate all the air.
5. Using a speculum, expose cervix and grasp the anterior lip with a single tooth tenaculum.
6. Sound the uterus for depth and direction. If the sound does not slide easily or drags, **do not force the injector through**. The cuff may tear if the cervical opening is too narrow.
7. Lubricate the distal endport (**B**) and cuff (**C**) for easy insertion. Carefully glide the instrument along the natural axis of the cervix to avoid injury.
8. Insert the injector fully into the uterus until the face of the cervical stop (**E**) abuts the external cervix. Slowly inflate the cuff with 3-5 cc of air until you notice the cervical stop being pulled up tightly against the cervix. The inflating cuff grasps the lower uterus between itself and the fixed cervical stop. Hold thumb on plunger as you remove the syringe from the inflation valve to prevent reflux of air back into the syringe.
9. To ensure that the cuff (**C**) has not ruptured during the procedure, check the tautness of the pilot balloon (**A**). A soft balloon indicates a ruptured or leaking cuff.
10. Pull on the instrument gently to see if the inflation of the cuff is adequate to prevent expulsion of the inflated cuff with normal intrauterine injection pressure. The less the cuff is inflated, the easier it can be expelled with excessive intrauterine injection pressure. If, however, the cuff is inflated beyond the amount of air needed to gently grasp the uterus, there will be more discomfort for the unanesthetized patient. This tense inflated cuff in the smaller uterus may also set up a "foreign body" like reaction causing utero-tubal spasm that may give the patient a physiological blockage of the tubes at the cornua.
11. The uterus is now grasped and the OS sealed. The speculum and tenaculum may be removed without disturbing the seal or losing the device. The patient may be repositioned in the dorsorecumbent position with easy access to the uterine cavity maintained. The plastic tube is pliable enough to be bent in the desired direction.
12. Injection media may be applied with a standard syringe and plastic stopcock or extenders as needed. Easy access to the uterus during Salpingoplasties may be achieved by attaching an extender to the luer fitting (**F**).
13. To remove the ZUI 4.0 Uterine Injector, insert the syringe deeply into the air valve (**A**) and deflate cuff. Carefully remove the instrument, checking carefully to be sure the device is intact and no parts remain in the vaginal canal.