

ENGLISH / EN

**INSORB**  
Absorbable | Subcuticular  
Skin Stapler

**REF 2030**

The INSORB Subcuticular Skin Stapler places an absorbable staple horizontally in the dermis to achieve an everted skin closure. The device presents tissue in the path of two surgically-sharpened needles to capture a precise 'bite' of dermis on both sides of the incision. A rigid, u-shaped absorbable staple with cleats secures the closure. INSORB Staples are made of an absorbable copolymer derived from lactic and glycolic acids which degrade in vivo by hydrolysis and then metabolized. Absorption begins as a loss of tensile strength without an appreciable loss of mass. At 10-12 weeks, the staple is approximately one-half its original mass, and the remainder is absorbed during the subsequent months.

- A - Handle
- B - Lever
- C - Compression Arms
- D - Needle Path
- E - Blue Triangles
- F - Nose
- G - Forceps Mate Location
- H - Staple Counter
- I - Absorbable Staple

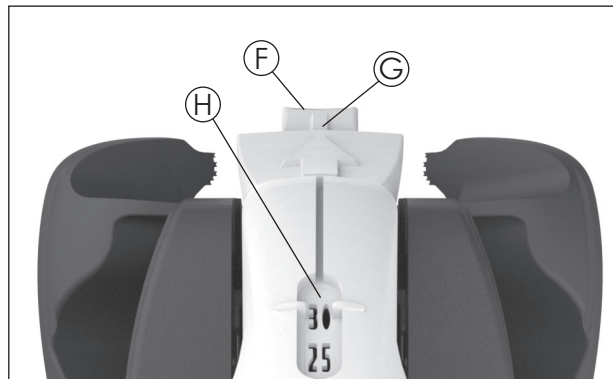
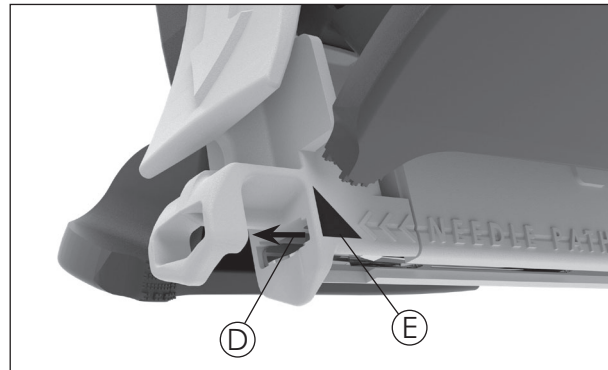
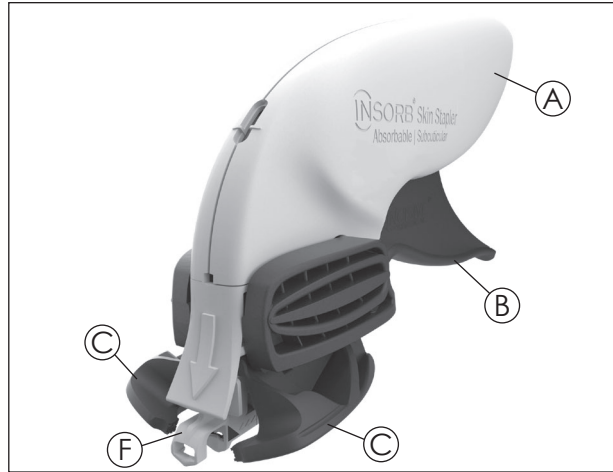
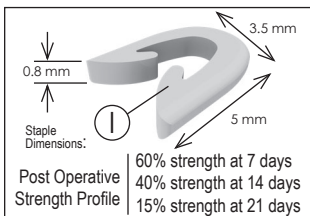

**IMPORTANT:**

Failure to properly follow the instructions may lead to serious surgical consequences. These directions are designed to assist in the use of the INSORB Stapler. They are NOT a reference to surgical stapling techniques.

**PRODUCT DESCRIPTION:**

The INSORB Subcuticular Skin Stapler is a sterile, single patient use device containing INSORB Absorbable Staples for skin closure.

**INDICATIONS:**

Synthetic absorbable INSORB Staples are intended for use in the subcuticular closure of skin where an absorbable tissue fastener is desired for temporary tissue approximation.

**CONTRAINDICATIONS:**

1. Do NOT use the staple on scar tissue if an effective tissue capture can not be achieved.
2. Do NOT place a staple where the needle path is obstructed or a collision with any object may occur.
3. Do NOT use the staple on tissue which is too thin to permit an effective tissue capture.
4. Do NOT use the staple on tissue which is too thick to permit an effective tissue capture.
5. Do NOT use when radiopacity is necessary or desired since INSORB staples are radiotransparent.
6. Do NOT use where prolonged tissue approximation beyond that needed for normal skin tissue closure is necessary or desired.

**PRECAUTION:**

**TENSION** - Placement of deep supporting sutures is required to ensure closure integrity when excessive tension on the wound edge is or may be present, e.g. high-tension areas, high BMI, excisions, and/or wounds that may experience significant swelling. These sutures must be placed at least 1cm from the wound edge to allow sufficient tissue to cover the Blue Triangles on the nose of Stapler. See graphic at right.

**ADVERSE REACTIONS:**

Adverse reactions may include wound separation, infection, bleeding, hematoma, seroma, skin edge necrosis, pain, acute inflammation, erythema, edema, swelling, excessive itching, irritation, bruising, drainage, prolonged wound eversion, surfacing staples, percutaneous staples, superficial staples, anxiety, and compromised cosmesis, e.g., keloid, hypertrophic scar, scar widening, discoloration, and hyperpigmentation.

**OTHER NOTES:**

- **FORCEPS** - Closure may also be completed with two (2) Adson Forceps or the INSORB|1 Forceps.
- **EXCISIONS** - If the Staples are used to close the deep dermal layer in excisional closures, a subcuticular running stitch placed above the Staples is encouraged.
- **NEEDLE DAMAGE**– ANY contact with a forceps or other object WILL cause damage to the needles and compromise performance. If ANY damage is suspected, or if the device is not operating smoothly, discard and replace.
- **SCAR TISSUE** –Full excision of all scar tissue to virgin tissue edges may be required to achieve an effective wound closure.
- **REMOVING STAPLE DURING SURGERY** - Grasp the back of the staple and pull firmly to extract.
- **POST-OPERATIVE WOUND ACCESS** - To partially or fully open the incision, use scissors to cut the backspan of the Staple(s). It is not necessary to remove staple fragments.
- **SINGLE PATIENT USE** - Do NOT resterilize. Staple strength is affected by heat, humidity, and radiation. Resterilization will compromise performance and wound integrity, which may result in a wound separation. Properly dispose of all opened products whether used or unused.
- **WOUND CARE** – The use of adhesive dressings or skin glue is encouraged for external wound protection. The INSORB Staple provides an interrupted closure which allows immediate post-operative drainage that may be noted at the first dressing change.
- **STORE AT 16-25°C (61-77°F)**
- **DO NOT EXPOSE TO 50°C (122°F)** – Avoid prolonged exposure to elevated temperatures. Do NOT use the staplers if the temperature circle on the front flap of the carton has changed to RED.

# INSORB Skin Closure Technique:

PREPARATION: Prior to use, remove the red cover by pulling upper thin tab out and forward.

1

## GRASP 5mm & LIFT

Using 1 Adson forceps, GRASP 5mm of the tissue at an apex or directly above a previously placed staple\* and LIFT to present tissue to the Stapler.

\* To ensure Staples are placed at 7mm intervals

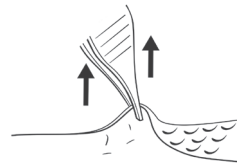

2

## MATE & FIRE

While maintaining the lift, place the nose into the wound to firmly MATE the Stapler with the Adson forceps directly below the arrow and FIRE the Stapler with a smooth squeeze until audible click, then release. Lift straight up to remove the Stapler - do not pull backwards.



NOTE: Grasping more than 5mm of tissue and/or not firmly mating the Stapler and forceps may result in placing Staples too deep and/or too far apart which may compromise wound integrity.

### To minimize superficial or external Staple placements:

- Keep Stapler level with plane of skin.
- Ensure both Blue Triangles are covered by skin. If necessary, rock Stapler side-to-side when in flaccid tissue or tight spaces, e.g. final Staple placement.
- Reverse the direction of closure for final Staple placement.

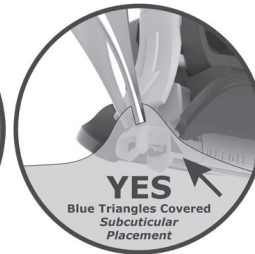

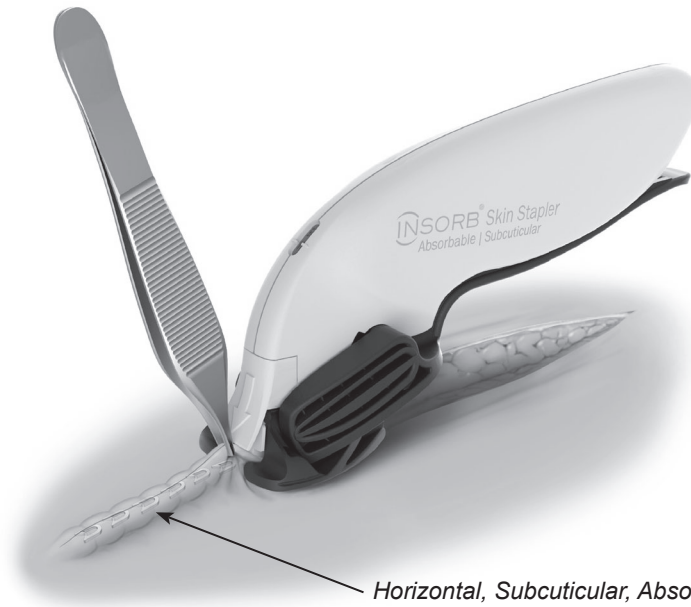

*Horizontal, Subcuticular, Absorbable Staples placed at 7mm intervals*

**NEEDLESTICK SAFETY:**

The INSORB Stapler complies with the Needlestick Safety and Prevention Act as a U.S. OSHA-defined SESIP (sharps with engineered sharps injury protections). The INSORB Stapler's built-in safety features effectively reduce the risk of an exposure incident. The Bloodborne Pathogens Standard clarifies the need for employers to select safer needle devices and to involve employees in identifying and selecting these devices.

Read IFU	Single Patient Use	Storage Temperatures	Store away from HEAT	Do NOT Use if damaged	Catalogue number	Batch Code	Expiration Date	Sterile - Gamma	CE Mark

Certifications: Not made with natural rubber latex. Not made with PVC or plasticizers used in PVC, like Di(2-ethylhexyl)phthalate (DEHP).  
 Not made with substances of Very High Concern (SVHC) per REACH (EC) No 1907/2006 (ECHA)  
 Not made with medicinal products. Not made with human blood derivatives. Not made with animal derived materials.

Caution: Rx ONLY - Federal (USA) law restricts this device to sale, distribution, and use by or on the order of, a physician.

Incisive Surgical, Inc.  
 95 Corporate Drive  
 Trumbull, CT 06611 USA  
 Phone: (800) 243-2974  
 Fax (800) 262-0105  
International  
 Phone: +1 (203) 601-9818  
 Fax +1 (203) 601-4747  
 www.coopersurgical.com

PI-2030EPC-EN • Rev. A • 03/2021

**EC REP**

Authorized Representative:  
 MPS Medical Product Service GmbH  
 Borngasse 20  
 35619 Braunfels Germany  
 49-6442-932673

